

ROPOS

CANADIAN SCIENTIFIC SUBMERSIBLE FACILITY

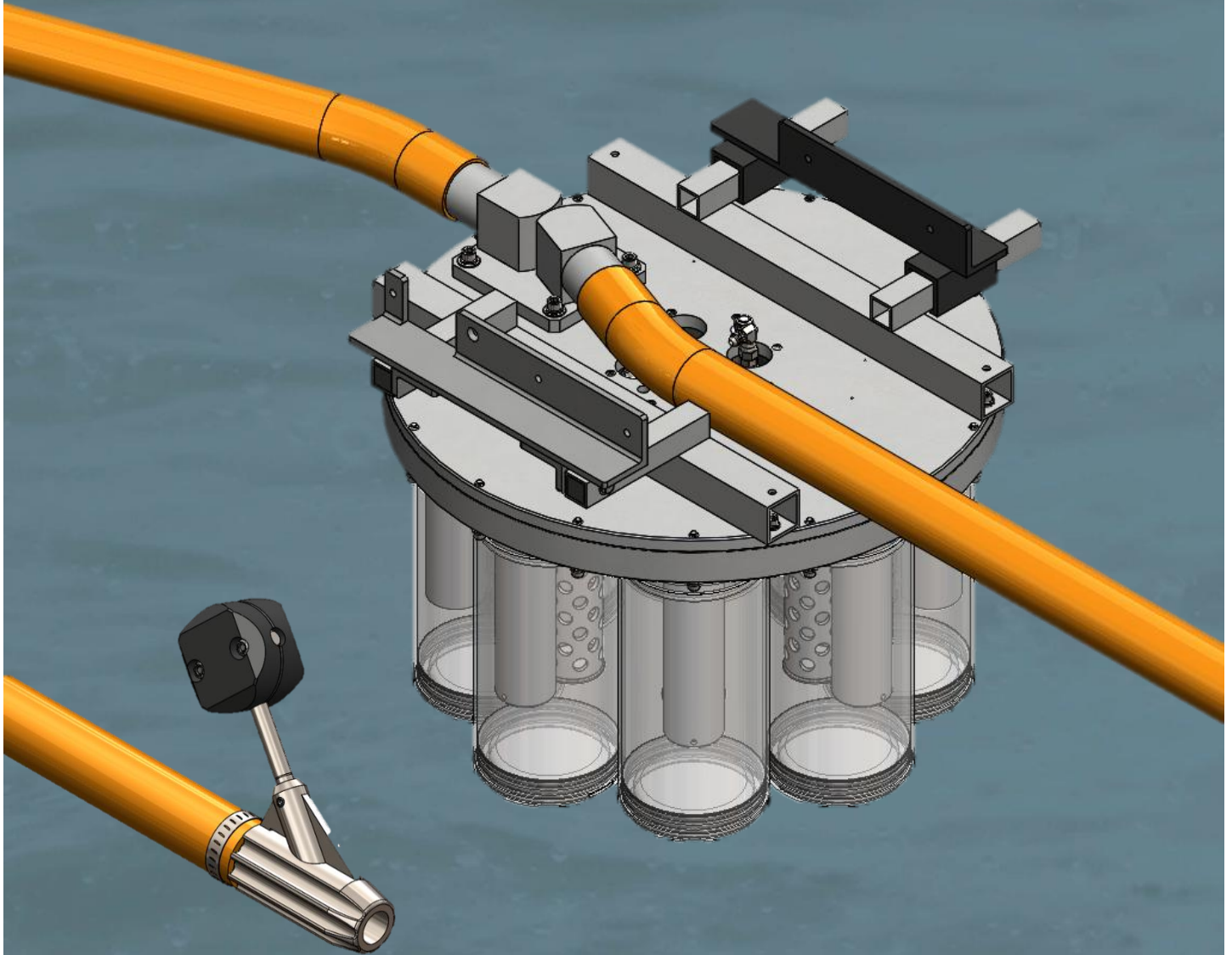

Suction Sampler

2L Jar Collection System

ROPOS.COM

Summary

The Suction Sampler is a hydraulically driven subsea sampling tool designed for efficient collection of biological, geological, and sediment samples. The system features a rotating carousel with eight collection jars and an integrated suction pump that draws material through an intake nozzle.

Mounted on an ROV and deployable via manipulator, the sampler allows operators to precisely position the intake nozzle in complex subsea environments.

Of the eight jars, seven are used for sample collection while one is designated as a flush jar, allowing the system to purge residual material from the intake hose prior to a new sampling event. This ensures cleaner samples and minimizes cross-contamination between deployments.

Each sample is isolated within its individual jar, providing reliable, repeatable sampling performance in deep-sea operations.

Key Features

- 8-position carousel sampling system (7 sample jars + 1 flush jar)
- Hydraulic-driven suction pump for controlled sample intake
- Ratcheting carousel mechanism for reliable jar indexing
- Interchangeable filter screens (125, 500, 1000 microns)
- Transparent, numbered jars for easy identification

Specifications

Sampling		
Jar Capacity	0.53gal (2L)	
Number of Jars	8 (7 sampling, 1 flush)	
Standard Filter Sizes	125, 500, 1000 microns	
Inlet Nozzle Diameter	1" (25.4mm)	
Extendable Range	Titan-4 Manipulator Range (see below)	
Hydraulics		
	Suction Pump Motor	Carousel Cylinder
Hydraulic Requirement	1000 psi @ 8gpm (70bar @ 30 L/min)	1000 psi (70bar)
Connections	2x -4 MJIC	2x -4 MJIC
Environmental		
Depth Rating	Full Ocean Depth	
Mechanical		
Carousel Construction	Anodized Aluminum	
Jar Construction	Polycarbonate	
Nozzle Construction	Stainless Steel	
Weight in Air (Filled w/Water)	106.0 lbs (48.0kg)	
Weight in Air (Empty)	59.9 lbs (27.2 kg)	
Weight in Water	22.5 lbs (10.2 kg)	